

# V470 & V520 High Efficiency Solid Varix Endmills

## 整體硬質合金高效益抗震銑刀

- **Unequal flute spacing for anti-vibration.**

不等分割設計大幅降低加工時產生的震動

- **Suitable for superalloy machining.**

適用於高溫合金加工

- **High removal rate for steel and stainless steel machining.**

適用於一般鋼料及不鏽鋼高去除率加工

- **Low cutting force and burr prevention.**

低切削阻力和抑制毛刺

METRIC

P	M	K	N	S	H
●	●	●		●	●

Excellent chip evacuation  
易排屑設計

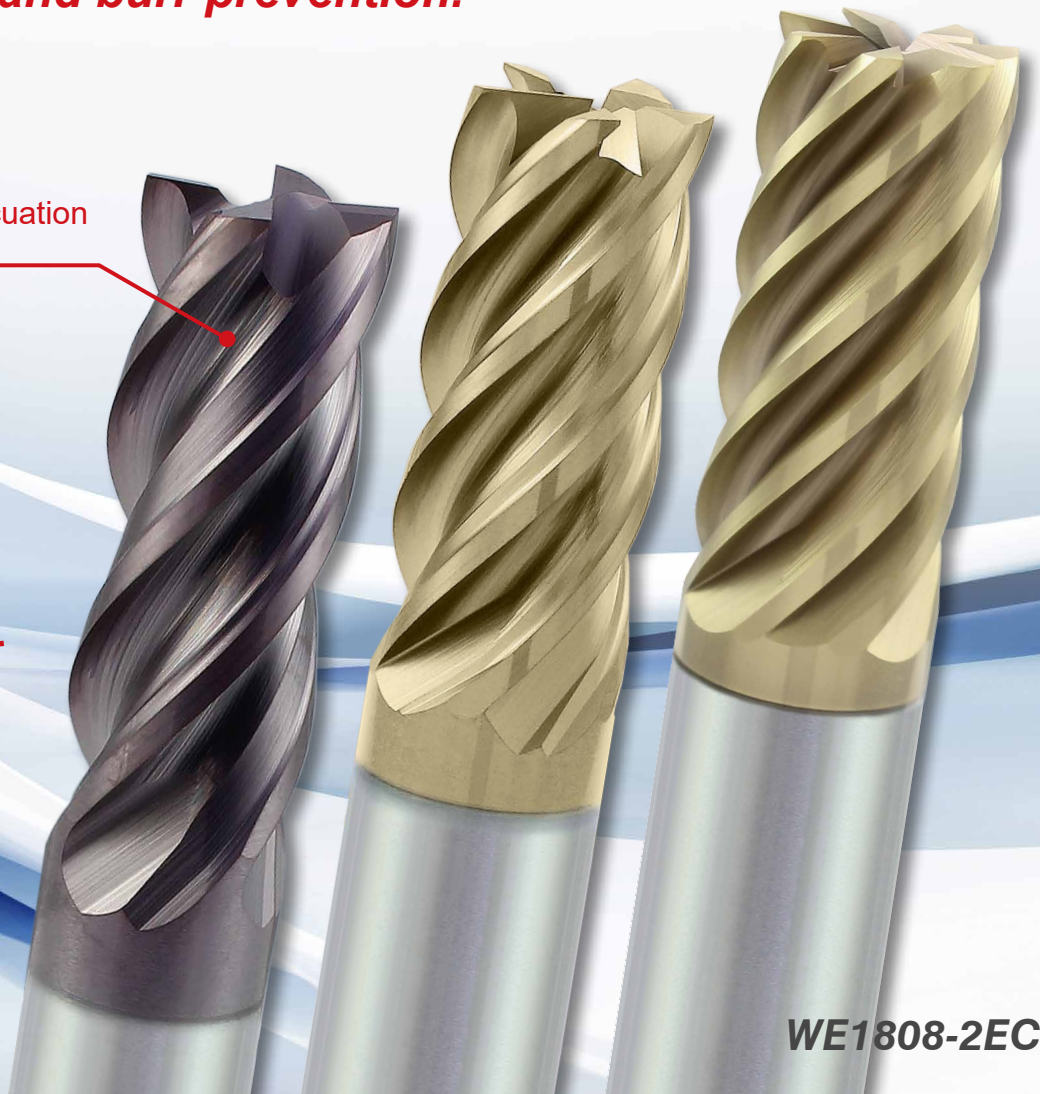
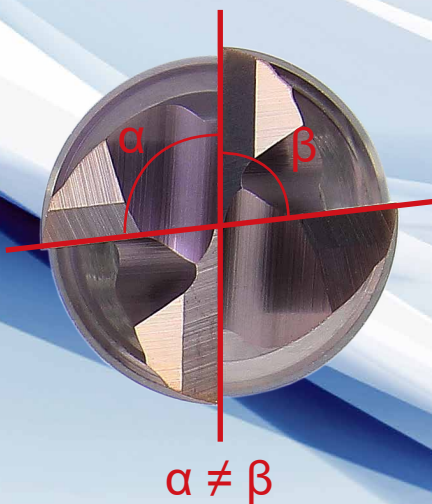













### Recommended Cutting Conditions 建議切削參數

※If the machine not stable, please reduce the feed about 20%.  
若機床條件較不穩定，請將進給率調降 20%

Working material 被加工材料	Cutting application 加工方式	ae (mm)	ap (mm)	Vc (m/min)	fz (mm/z)					
					4mm	6mm	8mm	10mm	12mm	16mm
Carbon steel (S45C) 中碳鋼	Slot milling 溝銑	1×d	0.5 ~ 1.0×d	80 ~ 145	0.025	0.030	0.040	0.050	0.060	0.080
	Side roughing 粗側銑	0.4 ~ 0.9×d	0.7 ~ 1.0×d	90 ~ 160	0.030	0.035	0.050	0.060	0.075	0.100
	Side finishing 精側銑	0.1 ~ 0.3×d	0.7 ~ 1.5×d	130 ~ 225	0.020	0.025	0.035	0.045	0.055	0.072
Carbon steel (S50C) 中高碳鋼	Slot milling 溝銑	1×d	0.5 ~ 1.0×d	70 ~ 130	0.025	0.030	0.040	0.050	0.060	0.080
	Side roughing 粗側銑	0.4 ~ 0.9×d	0.7 ~ 1.0×d	80 ~ 145	0.030	0.035	0.050	0.060	0.075	0.100
	Side finishing 精側銑	0.1 ~ 0.3×d	0.7 ~ 1.5×d	95 ~ 180	0.020	0.025	0.035	0.045	0.055	0.072
Tool steel (SKD) 工具鋼	Slot milling 溝銑	1×d	0.5 ~ 1.0×d	65 ~ 110	0.020	0.025	0.035	0.045	0.055	0.072
	Side roughing 粗側銑	0.4 ~ 0.9×d	0.7 ~ 1.0×d	70 ~ 130	0.030	0.035	0.045	0.055	0.070	0.088
	Side finishing 精側銑	0.1 ~ 0.3×d	0.7 ~ 1.5×d	90 ~ 160	0.020	0.025	0.035	0.040	0.050	0.064
Hardened steel & Superalloy 熱處理高硬鋼 & 高溫合金	Slot milling 溝銑	1×d	0.5 ~ 1.0×d	30 ~ 60	0.015	0.020	0.025	0.030	0.035	0.048
	Side roughing 粗側銑	0.4 ~ 0.9×d	0.7 ~ 1.0×d	50 ~ 90	0.015	0.020	0.030	0.035	0.040	0.056
	Side finishing 精側銑	0.1 ~ 0.3×d	0.7 ~ 1.5×d	65 ~ 120	0.020	0.025	0.035	0.040	0.050	0.064
Stainless steel (SUS304, SUS316) 不鏽鋼	Slot milling 溝銑	1×d	0.5 ~ 1.0×d	50 ~ 65	0.015	0.020	0.030	0.035	0.040	0.056
	Side roughing 粗側銑	0.4 ~ 0.9×d	0.7 ~ 1.0×d	65 ~ 100	0.020	0.025	0.035	0.045	0.055	0.072
	Side finishing 精側銑	0.1 ~ 0.3×d	0.7 ~ 1.5×d	80 ~ 110	0.020	0.025	0.035	0.040	0.050	0.064

