

V470 & V520 Solid Carbide Endmills for High Efficiency Machining

- *Unequal flute spacing for anti-vibration.*
- *Suitable for superalloy machining.*
- *High removal rate for steel and stainless steel machining.*
- *Low cutting force and burr prevention.*

INCH

P	M	K	N	S	H
●	●	●		●	●

Excellent chip evacuation

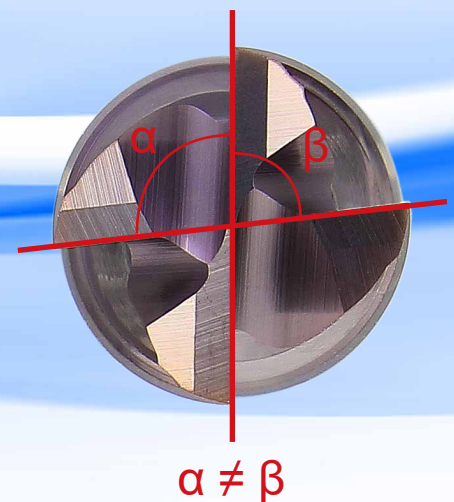

V470 Varix Carbide Endmills - Variable Spacing - 4F

■ EPS, EPC, EPF Series

- High removal rate for steel and stainless steel machining.
- Unequal flute spacing for anti-vibration.
- Low cutting force and burr prevention.
- UNICO coating includes Al, Ti, Cr, N elements.

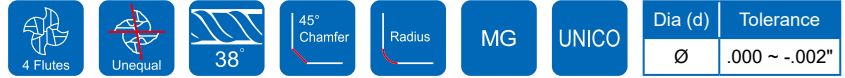
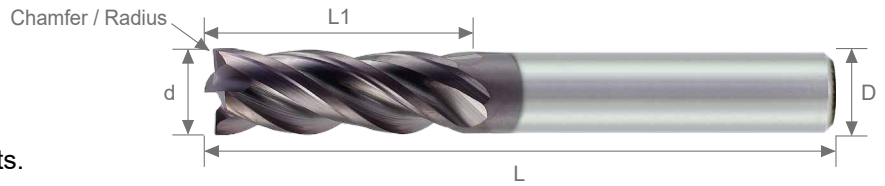

Work Material							
Carbon Steel (S45C, S55C)	Alloy Steel (SK, SCM)	Pre-Hardened Steel / Hardened Steel			Stainless Steel (SUS304, 316)	Cast Iron	Superalloy
		~ HRC 40	~ HRC 45	~ HRC 55			
◎	◎	◎	◎	○	◎	◎	

Order No.	Dia (d)	Flute Length (L1)	OAL (L)	Shank (D)	Chamfer / Radius	Flutes (F)
EPF2V40120210U	1/8	1/4	1 1/2	1/8	.010C	4
EPS2V40120200U	1/8	1/4	1 1/2	1/8	-	4
EPC2V40120215U	1/8	1/4	2 1/2	1/8	.015R	4
EPC4V40120515U	1/8	1/2	2	1/8	.015R	4
EPS4V40120500U	1/8	1/2	2	1/8	-	4
EPF4V40120510U	1/8	1/2	2	1/8	.010C	4
EPS9V40120500U	1/8	1/2	2 1/2	1/8	-	4
EPF2V40180310U	3/16	5/16	2 1/2	3/16	.010C	4
EPC2V40180315U	3/16	5/16	2 1/2	3/16	.015R	4
EPS7V40180300U	3/16	5/16	2 1/2	3/16	-	4
EPF3V40180610U	3/16	5/8	2 1/2	3/16	.010C	4
EPC8V40180615U	3/16	5/8	2 1/2	3/16	.015R	4
EPC8V40180630U	3/16	5/8	2 1/2	3/16	.030R	4
EPS8V40180600U	3/16	5/8	2 1/2	3/16	-	4
EPC2V40250330U	1/4	3/8	2	1/4	.030R	4
EPS2V40250300U	1/4	3/8	2	1/4	-	4
EPF2V40250315U	1/4	3/8	2	1/4	.015C	4
EPC3V40250715U	1/4	3/4	2 1/2	1/4	.015R	4
EPC3V40250730U	1/4	3/4	2 1/2	1/4	.030R	4
EPC3V40250760U	1/4	3/4	2 1/2	1/4	.060R	4
EPF3V40250715U	1/4	3/4	2 1/2	1/4	.015C	4
EPS3V40250700U	1/4	3/4	2 1/2	1/4	-	4
EPC4V40251015U	1/4	1	3	1/4	.015R	4
EPS4V40251000U	1/4	1	3	1/4	-	4
EPC5V40251215U	1/4	1 1/4	3	1/4	.015R	4
EPC5V40251230U	1/4	1 1/4	3	1/4	.030R	4
EPS5V40251200U	1/4	1 1/4	3	1/4	-	4

(continued)

V470 Varix Carbide Endmills - Variable Spacing - 4F

■ EPS, EPC, EPF Series

- High removal rate for steel and stainless steel machining.
- Unequal flute spacing for anti-vibration.
- Low cutting force and burr prevention.
- UNICO coating includes Al, Ti, Cr, N elements.

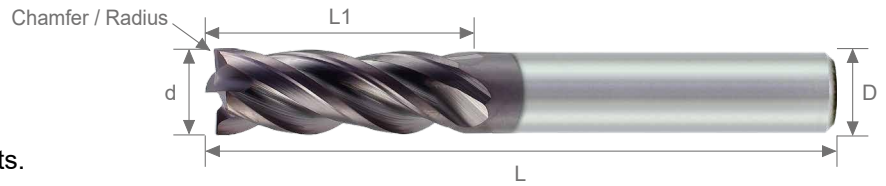

4 Flutes	Unequal	38°	45° Chamfer	Radius	MG	UNICO	Dia (d)	Tolerance
							Ø	.000 ~ -.002"

Order No.	Dia (d)	Flute Length (L1)	OAL (L)	Shank (D)	Chamfer / Radius	Flutes (F)
EPC2V40310530U	5/16	1/2	2 1/2	5/16	.030R	4
EPF2V40310515U	5/16	1/2	2 1/2	5/16	.015C	4
EPS2V40310500U	5/16	1/2	2 1/2	5/16	-	4
EPC2V40310715U	5/16	3/4	2 1/2	5/16	.015R	4
EPC2V40310730U	5/16	3/4	2 1/2	5/16	.030R	4
EPC2V40310760U	5/16	3/4	2 1/2	5/16	.060R	4
EPF2V40310715U	5/16	3/4	2 1/2	5/16	.015C	4
EPS2V40310700U	5/16	3/4	2 1/2	5/16	-	4
EPC4V40311230U	5/16	1 1/4	3	5/16	.030R	4
EPS4V40311200U	5/16	1 1/4	3	5/16	-	4
EPC2V40370815U	3/8	7/8	2 1/2	3/8	.015R	4
EPC2V40370830U	3/8	7/8	2 1/2	3/8	.030R	4
EPC2V40370860U	3/8	7/8	2 1/2	3/8	.060R	4
EPC2V40370890U	3/8	7/8	2 1/2	3/8	.090R	4
EPF2V40370820U	3/8	7/8	2 1/2	3/8	.020C	4
EPS2V40370800U	3/8	7/8	2 1/2	3/8	-	4
EPC3V40371015U	3/8	1	3	3/8	.015R	4
EPC3V40371030U	3/8	1	3	3/8	.030R	4
EPC3V40371060U	3/8	1	3	3/8	.060R	4
EPS3V40371000U	3/8	1	3	3/8	-	4
EPC4V40371530U	3/8	1 1/2	4	3/8	.030R	4
EPC4V40371560U	3/8	1 1/2	4	3/8	.060R	4
EPS4V40371500U	3/8	1 1/2	4	3/8	-	4
EPC7V40372530U	3/8	2 1/2	4	3/8	.030R	4
EPC7V40372560U	3/8	2 1/2	4	3/8	.060R	4

(continued)

V470 Varix Carbide Endmills - Variable Spacing - 4F

■ EPS, EPC, EPF Series

- High removal rate for steel and stainless steel machining.
- Unequal flute spacing for anti-vibration.
- Low cutting force and burr prevention.
- UNICO coating includes Al, Ti, Cr, N elements.

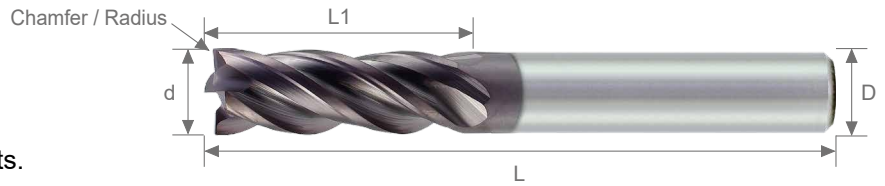

4 Flutes	Unequal	38°	45° Chamfer	Radius	MG	UNICO	Dia (d)	Tolerance
							∅	.000 ~ -.002"

Order No.	Dia (d)	Flute Length (L1)	OAL (L)	Shank (D)	Chamfer / Radius	Flutes (F)
EPF1V40430620U	7/16	5/8	2 3/4	7/16	.020C	4
EPS1V40430600U	7/16	5/8	2 3/4	7/16	-	4
EPF2V40430820U	7/16	7/8	2 3/4	7/16	.020C	4
EPS2V40430800U	7/16	7/8	2 3/4	7/16	-	4
EPC2V40501030U	1/2	1	3	1/2	.030R	4
EPC2V40501060U	1/2	1	3	1/2	.060R	4
EPS2V40501000U	1/2	1	3	1/2	-	4
EPF2V40501020U	1/2	1	3	1/2	.020C	4
EPC3V40501215U	1/2	1 1/4	3	1/2	.015R	4
EPC3V40501230U	1/2	1 1/4	3	1/2	.030R	4
EPC3V40501260U	1/2	1 1/4	3	1/2	.060R	4
EPC3V40501290U	1/2	1 1/4	3	1/2	.090R	4
EPC3V405012C0U	1/2	1 1/4	3	1/2	.120R	4
EPF3V40501220U	1/2	1 1/4	3	1/2	.020C	4
EPS3V40501200U	1/2	1 1/4	3	1/2	-	4
EPC3V40501530U	1/2	1 1/2	4	1/2	.030R	4
EPC3V40501560U	1/2	1 1/2	4	1/2	.060R	4
EPF3V40501520U	1/2	1 1/2	4	1/2	.020C	4
EPS3V40501500U	1/2	1 1/2	4	1/2	-	4
EPC4V40502030U	1/2	2	4	1/2	.030R	4
EPC4V40502060U	1/2	2	4	1/2	.060R	4
EPS4V40502000U	1/2	2	4	1/2	-	4

(continued)

V470 Varix Carbide Endmills - Variable Spacing - 4F

■ EPS, EPC, EPF Series

- High removal rate for steel and stainless steel machining.
- Unequal flute spacing for anti-vibration.
- Low cutting force and burr prevention.
- UNICO coating includes Al, Ti, Cr, N elements.

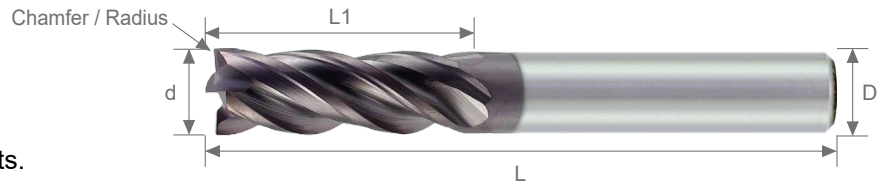

							Dia (d)	Tolerance
							∅	.000 ~ -.002"

Order No.	Dia (d)	Flute Length (L1)	OAL (L)	Shank (D)	Chamfer / Radius	Flutes (F)
EPC2V40621230U	5/8	1 1/4	3 1/2	5/8	.030R	4
EPC2V40621260U	5/8	1 1/4	3 1/2	5/8	.060R	4
EPC2V40621290U	5/8	1 1/4	3 1/2	5/8	.090R	4
EPC2V406212C0U	5/8	1 1/4	3 1/2	5/8	.120R	4
EPS2V40621200U	5/8	1 1/4	3 1/2	5/8	-	4
EPF2V40621220U	5/8	1 1/4	3 1/2	5/8	.020C	4
EPC2V40751530U	3/4	1 1/2	4	3/4	.030R	4
EPC2V40751560U	3/4	1 1/2	4	3/4	.060R	4
EPC2V40751590U	3/4	1 1/2	4	3/4	.090R	4
EPF2V40751520U	3/4	1 1/2	4	3/4	.020C	4
EPS2V40751500U	3/4	1 1/2	4	3/4	-	4
EPF2V41002020U	1	2	5	1	.020C	4
EPS2V41002000U	1	2	5	1	-	4
EPC2V41002230U	1	2 1/4	5	1	.030R	4
EPC2V41002260U	1	2 1/4	5	1	.060R	4
EPS2V41002200U	1	2 1/4	5	1	-	4
EPF2V41002220U	1	2 1/4	5	1	.020C	4

V520 Varix Carbide Endmills - Variable Spacing - 4F

EMS, EMC, EMF Series

- High removal rate for stainless steel machining.
- Unequal flute spacing for anti-vibration.
- Low cutting force and burr prevention.
- SICO coating includes Al, Ti, Si, N elements.

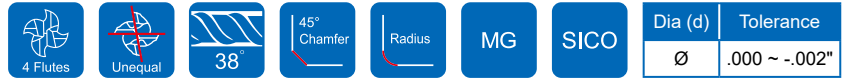
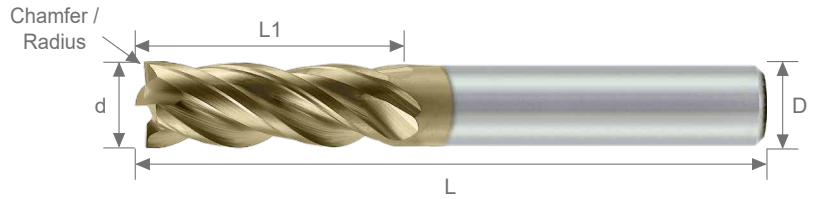

Work Material							
Carbon Steel (S45C, S55C)	Alloy Steel (SK, SCM)	Pre-Hardened Steel / Hardened Steel			Stainless Steel (SUS304, 316)	Cast Iron	Superalloy
		~ HRC 40	~ HRC 45	~ HRC 55			
◎	◎	◎	◎	◎	◎	◎	◎

Order No.	Dia (d)	Flute Length (L1)	OAL (L)	Shank (D)	Chamfer / Radius	Flutes (F)
EMF2V40120210S	1/8	1/4	1 1/2	1/8	.010C	4
EMS2V40120200S	1/8	1/4	1 1/2	1/8	-	4
EMC2V40120215S	1/8	1/4	2 1/2	1/8	.015R	4
EMF2V40180310S	3/16	5/16	2 1/2	3/16	.010C	4
EMC2V40180315S	3/16	5/16	2 1/2	3/16	.015R	4
EMF3V40180610S	3/16	5/8	2 1/2	3/16	.010C	4
EMC2V40250330S	1/4	3/8	2	1/4	.030R	4
EMS2V40250300S	1/4	3/8	2	1/4	-	4
EMF2V40250315S	1/4	3/8	2	1/4	.015C	4
EMC3V40250715S	1/4	3/4	2 1/2	1/4	.015R	4
EMC3V40250730S	1/4	3/4	2 1/2	1/4	.030R	4
EMC3V40250760S	1/4	3/4	2 1/2	1/4	.060R	4
EMF3V40250715S	1/4	3/4	2 1/2	1/4	.015C	4
EMS3V40250700S	1/4	3/4	2 1/2	1/4	-	4
EMC2V40310530S	5/16	1/2	2 1/2	5/16	.030R	4
EMF2V40310515S	5/16	1/2	2 1/2	5/16	.015C	4
EMS2V40310500S	5/16	1/2	2 1/2	5/16	-	4
EMC2V40310715S	5/16	3/4	2 1/2	5/16	.015R	4
EMC2V40310730S	5/16	3/4	2 1/2	5/16	.030R	4
EMC2V40310760S	5/16	3/4	2 1/2	5/16	.060R	4
EMF2V40310715S	5/16	3/4	2 1/2	5/16	.015C	4
EMS2V40310700S	5/16	3/4	2 1/2	5/16	-	4

(continued)

V520 Varix Carbide Endmills - Variable Spacing - 4F

EMS, EMC, EMF Series

- High removal rate for stainless steel machining.
- Unequal flute spacing for anti-vibration.
- Low cutting force and burr prevention.
- SICO coating includes Al, Ti, Si, N elements.

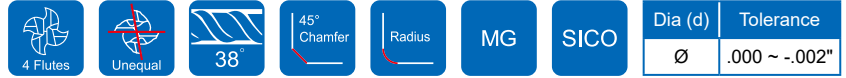
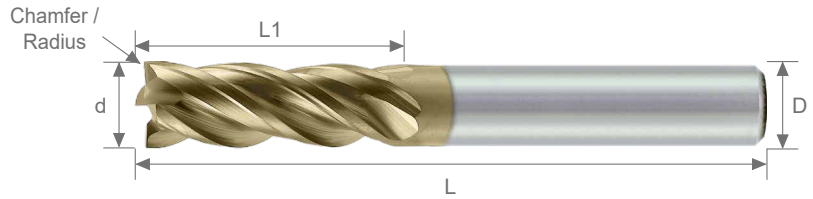

Order No.	Dia (d)	Flute Length (L1)	OAL (L)	Shank (D)	Chamfer / Radius	Flutes (F)
EMC2V40370815S	3/8	7/8	2 1/2	3/8	.015R	4
EMC2V40370830S	3/8	7/8	2 1/2	3/8	.030R	4
EMC2V40370860S	3/8	7/8	2 1/2	3/8	.060R	4
EMC2V40370890S	3/8	7/8	2 1/2	3/8	.090R	4
EMF2V40370820S	3/8	7/8	2 1/2	3/8	.020C	4
EMS2V40370800S	3/8	7/8	2 1/2	3/8	-	4
EMC3V40371015S	3/8	1	3	3/8	.015R	4
EMC3V40371030S	3/8	1	3	3/8	.030R	4
EMC3V40371060S	3/8	1	3	3/8	.060R	4
EMS3V40371000S	3/8	1	3	3/8	-	4
EMC2V40501030S	1/2	1	3	1/2	.030R	4
EMC2V40501060S	1/2	1	3	1/2	.060R	4
EMS2V40501000S	1/2	1	3	1/2	-	4
EMF2V40501020S	1/2	1	3	1/2	.020C	4
EMC3V40501215S	1/2	1 1/4	3	1/2	.015R	4
EMC3V40501230S	1/2	1 1/4	3	1/2	.030R	4
EMC3V40501260S	1/2	1 1/4	3	1/2	.060R	4
EMC3V40501290S	1/2	1 1/4	3	1/2	.090R	4
EMC3V405012C0S	1/2	1 1/4	3	1/2	.120R	4
EMF3V40501220S	1/2	1 1/4	3	1/2	.020C	4
EMS3V40501200S	1/2	1 1/4	3	1/2	-	4
EMC2V40621230S	5/8	1 1/4	3 1/2	5/8	.030R	4
EMC2V40621260S	5/8	1 1/4	3 1/2	5/8	.060R	4
EMC2V40621290S	5/8	1 1/4	3 1/2	5/8	.090R	4
EMC2V406212C0S	5/8	1 1/4	3 1/2	5/8	.120R	4
EMS2V40621200S	5/8	1 1/4	3 1/2	5/8	-	4
EMF2V40621220S	5/8	1 1/4	3 1/2	5/8	.020C	4
EMC2V40751530S	3/4	1 1/2	4	3/4	.030R	4
EMC2V40751560S	3/4	1 1/2	4	3/4	.060R	4
EMC2V40751590S	3/4	1 1/2	4	3/4	.090R	4
EMF2V40751520S	3/4	1 1/2	4	3/4	.020C	4
EMS2V40751500S	3/4	1 1/2	4	3/4	-	4
EMF2V41002020S	1	2	5	1	.020C	4
EMS2V41002000S	1	2	5	1	-	4

V520 Varix Carbide Endmills - Variable Spacing - 5F

EMC Series

- Suitable for superalloy machining.
- Unequal flute spacing for anti-vibration.
- Low cutting force and outstanding finishing for mold & die.
- SICO coating includes Al, Ti, Si, N elements.

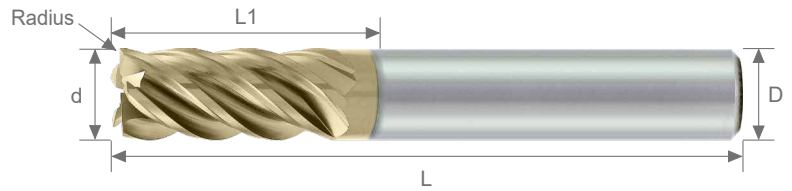

Work Material							
Carbon Steel (S45C, S55C)	Alloy Steel (SK, SCM)	Pre-Hardened Steel / Hardened Steel			Stainless Steel (SUS304, 316)	Cast Iron	Superalloy
		~ HRC 40	~ HRC 45	~ HRC 55			
◎	◎	◎	◎	◎	◎	◎	

Order No.	Dia (d)	Flute Length (L1)	OAL (L)	Shank (D)	Radius	Flutes (F)
EMC3V50250715S	1/4	3/4	2 1/2	1/4	.015R	5
EMC3V50250730S	1/4	3/4	2 1/2	1/4	.030R	5
EMC3V50250760S	1/4	3/4	2 1/2	1/4	.060R	5
EMC2V50310715S	5/16	3/4	2 1/2	5/16	.015R	5
EMC2V50310730S	5/16	3/4	2 1/2	5/16	.030R	5
EMC2V50310760S	5/16	3/4	2 1/2	5/16	.060R	5
EMC3V50371015S	3/8	1	3	3/8	.015R	5
EMC3V50371030S	3/8	1	3	3/8	.030R	5
EMC3V50371060S	3/8	1	3	3/8	.060R	5
EMC3V50371090S	3/8	1	3	3/8	.090R	5
EMC3V50501215S	1/2	1 1/4	3	1/2	.015R	5
EMC3V50501230S	1/2	1 1/4	3	1/2	.030R	5
EMC3V50501260S	1/2	1 1/4	3	1/2	.060R	5
EMC3V50501290S	1/2	1 1/4	3	1/2	.090R	5
EMC3V505012C0S	1/2	1 1/4	3	1/2	.120R	5
EMC3V50621630S	5/8	1 5/8	3 1/2	5/8	.030R	5
EMC3V50621660S	5/8	1 5/8	3 1/2	5/8	.060R	5
EMC3V50621690S	5/8	1 5/8	3 1/2	5/8	.090R	5
EMC3V506216C0S	5/8	1 5/8	3 1/2	5/8	.120R	5

V520 Varix Carbide Endmills - Variable Spacing - 7F

EMC Series

- Suitable for superalloy machining.
- Unequal flute spacing for anti-vibration.
- Low cutting force and outstanding finishing for mold & die.
- SICO coating includes Al, Ti, Si, N elements.

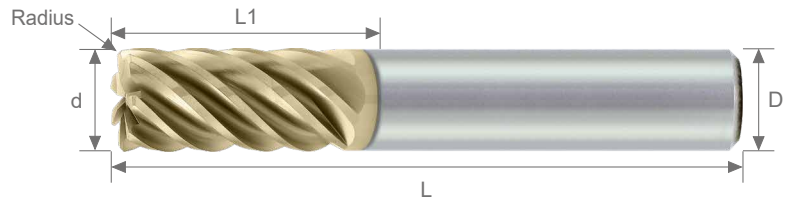

Work Material							
Carbon Steel (S45C, S55C)	Alloy Steel (SK, SCM)	Pre-Hardened Steel / Hardened Steel			Stainless Steel (SUS304, 316)	Cast Iron	Superalloy
		~ HRC 40	~ HRC 45	~ HRC 55			
◎	◎	◎	◎	◎	◎	◎	◎

Order No.	Dia (d)	Flute Length (L1)	OAL (L)	Shank (D)	Radius	Flutes (F)
EMC3V70250715S	1/4	3/4	2 1/2	1/4	.015R	7
EMC3V70250730S	1/4	3/4	2 1/2	1/4	.030R	7
EMC2V70310715S	5/16	3/4	2 1/2	5/16	.015R	7
EMC2V70310730S	5/16	3/4	2 1/2	5/16	.030R	7
EMC3V70371015S	3/8	1	3	3/8	.015R	7
EMC3V70371030S	3/8	1	3	3/8	.030R	7
EMC3V70371060S	3/8	1	3	3/8	.060R	7
EMC3V70501215S	1/2	1 1/4	3	1/2	.015R	7
EMC3V70501230S	1/2	1 1/4	3	1/2	.030R	7
EMC3V70501260S	1/2	1 1/4	3	1/2	.060R	7
EMC3V70501290S	1/2	1 1/4	3	1/2	.090R	7
EMC3V705012C0S	1/2	1 1/4	3	1/2	.120R	7
EMC3V70621630S	5/8	1 5/8	3 1/2	5/8	.030R	7
EMC3V70621660S	5/8	1 5/8	3 1/2	5/8	.060R	7
EMC3V70621690S	5/8	1 5/8	3 1/2	5/8	.090R	7
EMC3V706216C0S	5/8	1 5/8	3 1/2	5/8	.120R	7

Recommended Cutting Conditions

Recommended Cutting Conditions

※If the machine not stable, please reduce the feed about 20%.

Working Material	Cutting Application	ae	ap	SFM	fz (inch/z)				
					1/8	1/4	5/16	3/8	1/2
Carbon steel (S45C)	Slot milling	1×d	0.5 ~ 1.0×d	260 ~ 475	.0008	.0012	.0016	.0019	.0025
	Side roughing	0.4 ~ 0.9×d	0.7 ~ 1.0×d	295 ~ 525	.0009	.0015	.0020	.0023	.0031
	Side finishing	0.1 ~ 0.3×d	0.7 ~ 1.5×d	425 ~ 740	.0006	.0010	.0014	.0017	.0023
Carbon steel (S50C)	Slot milling	1×d	0.5 ~ 1.0×d	230 ~ 430	.0008	.0012	.0016	.0019	.0025
	Side roughing	0.4 ~ 0.9×d	0.7 ~ 1.0×d	260 ~ 475	.0009	.0015	.0020	.0023	.0031
	Side finishing	0.1 ~ 0.3×d	0.7 ~ 1.5×d	310 ~ 590	.0006	.0010	.0014	.0017	.0023
Tool Steel (SKD)	Slot milling	1×d	0.5 ~ 1.0×d	215 ~ 360	.0006	.0010	.0014	.0017	.0023
	Side roughing	0.4 ~ 0.9×d	0.7 ~ 1.0×d	230 ~ 430	.0009	.0015	.0018	.0021	.0029
	Side finishing	0.1 ~ 0.3×d	0.7 ~ 1.5×d	295 ~ 525	.0006	.0010	.0014	.0015	.0021
Hardened steel & Superalloy	Slot milling	1×d	0.5 ~ 1.0×d	100 ~ 200	.0005	.0008	.0010	.0011	.0015
	Side roughing	0.4 ~ 0.9×d	0.7 ~ 1.0×d	165 ~ 300	.0005	.0008	.0012	.0013	.0017
	Side finishing	0.1 ~ 0.3×d	0.7 ~ 1.5×d	215 ~ 395	.0006	.0010	.0014	.0015	.0021
Stainless steel (SUS304, SUS316)	Slot milling	1×d	0.5 ~ 1.0×d	165 ~ 215	.0005	.0008	.0012	.0013	.0017
	Side roughing	0.4 ~ 0.9×d	0.7 ~ 1.0×d	215 ~ 330	.0006	.0010	.0014	.0017	.0023
	Side finishing	0.1 ~ 0.3×d	0.7 ~ 1.5×d	260 ~ 360	.0006	.0010	.0014	.0015	.0021

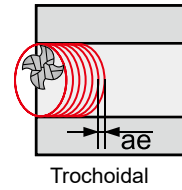
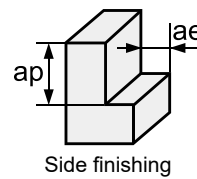
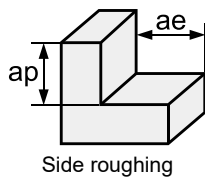
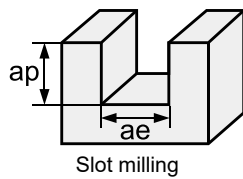

WINSTAR CUTTING TECHNOLOGIES CORP.

No. 10, Gongye 6th Road, Tainan Technology Industrial Park,
Tainan City 709, Taiwan

TEL : +886-6-3840386

FAX : +886-6-3840387

www.winstarcutting.com

info@winstarcutting.com